

Lobe knobs with solid section

Technopolymer, pad

MATERIAL

Glass-fibre reinforced polyamide based (PA) technopolymer, black colour, matte finish.

STANDARD EXECUTIONS

- **VC.692-SST-p-PO:** AISI 303 stainless steel threaded stud, chamfered end with acetal resin (POM) pad.
- **VC.692-SST-p-PB:** AISI 303 stainless steel threaded stud, chamfered end with brass pad.

FEATURES AND APPLICATIONS

The chamfered end with bolt avoids to damage the surface of contact even in case of strong clamping.

Standard executions either with brass or acetal resin pad.



ELESA Original design

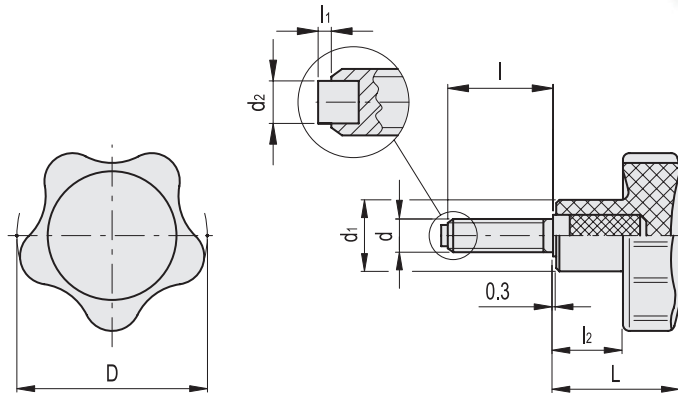

VC.692-SST-p-PO

STAINLESS STEEL

Code	Description	D	d6g	L	d1	d2	l	l1	l2	⚖️
166282	VC.692/32-SST-p-M6x16-PO	32	M6	22.5	14	4	16	1.5	12.5	15
166283	VC.692/32-SST-p-M6x20-PO	32	M6	22.5	14	4	20	1.5	12.5	16
166284	VC.692/32-SST-p-M6x30-PO	32	M6	22.5	14	4	30	1.5	12.5	19
166401	VC.692/40-SST-p-M8x20-PO	40	M8	26	15	5	20	1.8	14	28
166403	VC.692/40-SST-p-M8x30-PO	40	M8	26	15	5	30	1.8	14	32
166405	VC.692/40-SST-p-M8x40-PO	40	M8	26	15	5	40	1.8	14	36
166511	VC.692/50-SST-p-M10x20-PO	50	M10	31	18	6	20	2	17	47
166513	VC.692/50-SST-p-M10x30-PO	50	M10	31	18	6	30	2	17	57
166515	VC.692/50-SST-p-M10x40-PO	50	M10	31	18	6	40	2	17	66

VC.692-SST-p-PB

STAINLESS STEEL

Code	Description	D	d6g	L	d1	d2	l	l1	l2	⚖️
166182	VC.692/25 SST-p-M5x16-PB	25	M5	20	12	3	16	1.5	10	12
166184	VC.692/25 SST-p-M5x25-PB	25	M5	20	12	3	25	1.5	10	12
166292	VC.692/32-SST-p-M6x16-PB	32	M6	22.5	14	4	16	1.5	12.5	16
166293	VC.692/32-SST-p-M6x20-PB	32	M6	22.5	14	4	20	1.5	12.5	17
166294	VC.692/32-SST-p-M6x30-PB	32	M6	22.5	14	4	30	1.5	12.5	20
166411	VC.692/40-SST-p-M8x20-PB	40	M8	26	15	5	20	1.8	14	29
166413	VC.692/40-SST-p-M8x30-PB	40	M8	26	15	5	30	1.8	14	33
166415	VC.692/40-SST-p-M8x40-PB	40	M8	26	15	5	40	1.8	14	37
166521	VC.692/50-SST-p-M10x20-PB	50	M10	31	18	6	20	2	17	48
166523	VC.692/50-SST-p-M10x30-PB	50	M10	31	18	6	30	2	17	58
166525	VC.692/50-SST-p-M10x40-PB	50	M10	31	18	6	40	2	17	67



2

Clamping knobs