

Cranked handles

Cast iron

SPECIFICATION

Types

- Type **F**: with fixed handle
- Type **D**: with revolving handle

Crank handle body
Cast iron (GG)

- plastic coated, black, textured finish
- hub machined

Fixed handles DIN 39 (see page 565)
Steel zinc plated, blue passivated

Revolving handles DIN 98 (see page 579)
Steel zinc plated, blue passivated

INFORMATION

The hub bores d_1 H7 are not provided for in the official standard sheet.

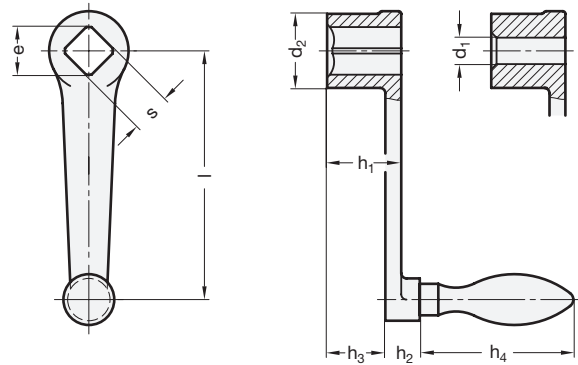

* Complete with types of the Cranked handles (F or D)

F fixed handle
D revolving handle

DIN 469

Description	l	s H11	e min.	d1 H7	d2	h1	h2	h3 ≈	h4 ≈ Type D	h4 ≈ Type F	Ø Handle	⚖
DIN 469-63-B6-*	63	-	13.1	B 6	20	20	11	15	54.5	50	16	125
DIN 469-63-V10-*	63	V 10	13.1	-	20	20	11	15	54.5	50	16	110
DIN 469-80-B8-*	80	-	13.1	B 8	24	24	13	18	61	56	18	203
DIN 469-80-V10-*	80	V 10	13.1	-	24	24	13	18	61	56	18	179
DIN 469-80-V12-*	80	V 12	13.1	-	24	24	13	18	61	56	18	170
DIN 469-100-B10-*	100	-	16.1	B 10	28	28	13	21	67	64	20	288
DIN 469-100-V12-*	100	V 12	16.1	-	28	28	13	21	67	64	20	271
DIN 469-100-V14-*	100	V 14	16.1	-	28	28	13	21	67	64	20	264
DIN 469-125-B10-*	125	-	18.1	B 10	34	34	14	26	76	72	22	458
DIN 469-125-V14-*	125	V 14	18.1	-	34	34	14	26	76	72	22	434
DIN 469-125-V17-*	125	V 17	18.1	-	34	34	14	26	76	72	22	414
DIN 469-160-B14-*	160	-	22.2	B 14	38	38	14	29	83	80	25	677
DIN 469-160-V17-*	160	V 17	22.2	-	38	38	14	29	83	80	25	642
DIN 469-160-V19-*	160	V 19	22.2	-	38	38	14	29	83	80	25	604
DIN 469-200-B17-*	200	-	25.2	B 17	44	44	21	34	96.5	90	28	1021
DIN 469-200-V19-*	200	V 19	25.2	-	44	44	21	34	96.5	90	28	998
DIN 469-200-V22-*	200	V 22	25.2	-	44	44	21	34	96.5	90	28	970
DIN 469-250-B17-*	250	-	28.2	B 17	48	48	21	36	105.5	100	32	1412
DIN 469-250-V22-*	250	V 22	28.2	-	48	48	21	36	105.5	100	32	1332
DIN 469-250-V24-*	250	V 24	28.2	-	48	48	21	36	105.5	100	32	1281

Weight type F

