

## Cabinet "U" handles

Aluminium

### SPECIFICATION

#### Types

- Type **A**: Mounting from the back (threaded blind bore)
- Type **B**: Mounting from the operator's side

Aluminium

plastic coated

black, RAL 9005, textured finish **SW**

silver, RAL 9006, textured finish **SR**

anodized, natural colour **EL**

blank, ground **BL**

### INFORMATION

Cabinet "U" handles GN 565.3 are suitable for applications where lower „lifting forces are required such as on lids or protective machine covers.

The countersunk holes of type B allow fixing with self tapping screws or countersunk rivets.

The manufacturing process (bending) allows the production of **special lengths** in relatively small quantities.

### TECHNICAL INFORMATION

- Load rating information (see page A35)

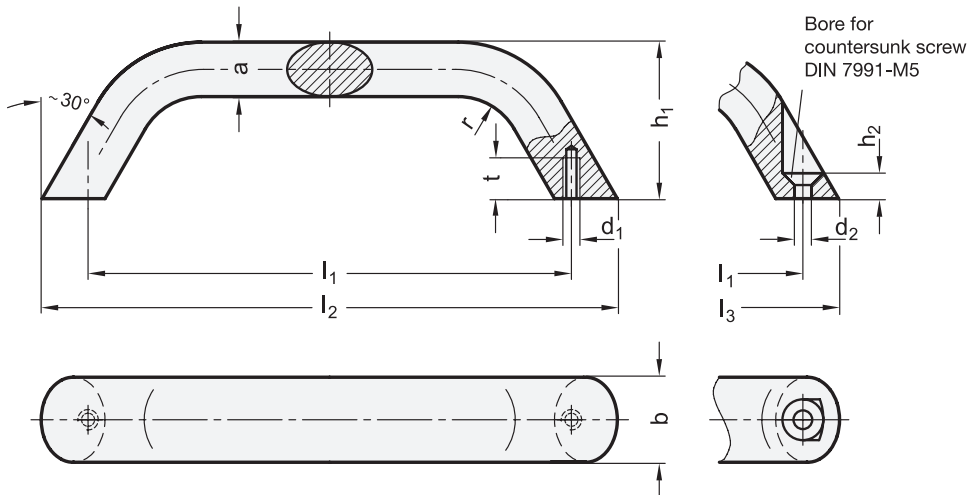

\* Complete with colour index of the Cabinet "U" handles (SW, SR, EL or BL)

SW RAL9005  
 SR RAL9006  
 EL anodized  
 BL blank

### GN 565.3

Description	b	l1 ±0.25	l2	l3 ≈	a	d1	d2	h1	h2	r	t min.	⚖
GN 565.3-20-120-A-*	20	120	142	-	13	M 5	-	41	-	13	10	86
GN 565.3-20-160-A-*	20	160	182	-	13	M 5	-	45	-	13	10	115
GN 565.3-20-120-B-*	20	120	-	137	13	-	5.3	41	5	13	10	82
GN 565.3-20-160-B-*	20	160	-	177	13	-	5.3	45	5	13	10	101

