

T-Handles

Aluminium

SPECIFICATION

Aluminium

plastic coated

black, RAL 9005, textured finish **SW**

silver, RAL 9006, textured finish **SR**

blank **BL**

tumbled, flash mark not visible

INFORMATION

T-Handles GN 563.2 can be used as either operating handles or for clamping purposes, producing high clamping forces.

T-Handles are produced using a stamping process which yields a high density material of high strength and a smooth surface.

An original ELESA-Design, produced in metal with permission of ELESA s. p. a.

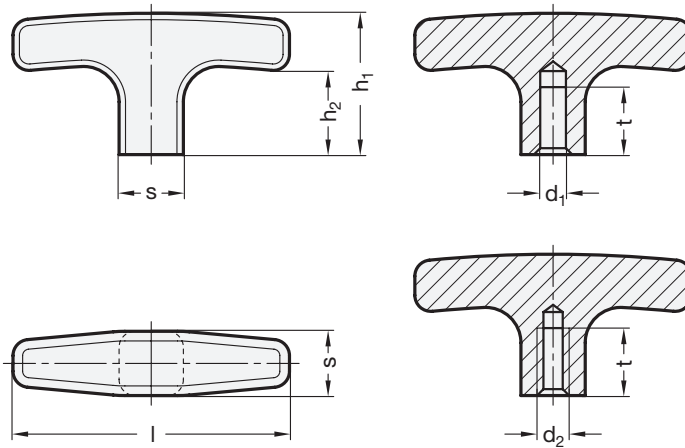

* Complete with colour index of the T-Handles (SW, SR or BL)

SW RAL9005 **SR** RAL9006 **BL** blank

GN 563.2

Description	l	d1 H7	d2	h1	h2	s	t min.	Δ
GN 563.2-55-B6-*	55	B 6	-	33	22	14	12	30
GN 563.2-67-B8-*	67	B 8	-	37	25	16	16	45
GN 563.2-80-B8-*	80	B 8	-	41	26	20	16	80
GN 563.2-55-M6-*	55	-	M 6	33	22	14	12	29
GN 563.2-55-M8-*	55	-	M 8	33	22	14	12	40
GN 563.2-67-M8-*	67	-	M 8	37	25	16	16	45
GN 563.2-80-M8-*	80	-	M 8	41	26	20	16	80
GN 563.2-80-M10-*	80	-	M 10	41	26	20	16	61

