

## Spherical washers

Steel / Stainless Steel

### SPECIFICATION

#### Version in Steel

##### Types

- Type **C**: male
- Type **D**: female  $d_4 = d_3$
- Type **G**: female  $d_4 > d_3$

##### Type **C / D**

case hardening steel

case hardened

all round depth 0.2 to 0.4 mm

hardness (550 + 100) HV 10

##### Type **G**

Heat-treatable Steel

tempered

hardness (350 + 80) HV 30

#### Version in Stainless Steel

##### Types

- Type **C**: male
- Type **D**: female  $d_4 = d_3$

Stainless Steel AISI 303 **NI**

not hardened

Stainless Steel AISI 316 **A4**

not hardened

### INFORMATION

Spherical washers DIN 6319 are used for clamping on non-parallel surfaces.

Female washers Type G are mainly used on elongated holes.

When utilizing hexagon nuts with spherical seating DIN 6330 (see page 988 ) the male washer is redundant.

#### ON REQUEST (STEEL VERSION)

- Not hardened spherical washers.

### TECHNICAL INFORMATION

- ISO-Fundamental Tolerances (see page A21)
- Stainless Steel characteristics (see page A26)



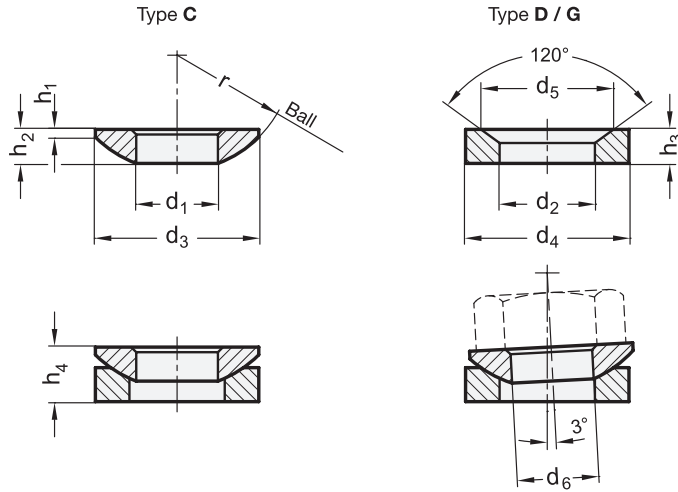

DIN 6319

Description	d1 H13	d2 H13	d3	d4	d5	d6	h1	h2	h3	h4	r	Transferable static bolt force in kN max.	⚖
DIN 6319-6,4-C	6.4	-	12	-	-	M 6	0.7	2.3	-	-	9	9	1
DIN 6319-8,4-C	8.4	-	17	-	-	M 8	0.6	3.2	-	-	12	17	2
DIN 6319-10,5-C	10.5	-	21	-	-	M 10	0.8	4	-	-	15	26	5
DIN 6319-13-C	13	-	24	-	-	M 12	1.1	4.6	-	-	17	38	7
DIN 6319-15-C	15	-	28	-	-	M 14	1.2	5	-	-	22	53	12
DIN 6319-17-C	17	-	30	-	-	M 16	1.3	5.3	-	-	22	73	13
DIN 6319-21-C	21	-	36	-	-	M 20	2	6.3	-	-	27	117	30
DIN 6319-25-C	25	-	44	-	-	M 24	2.4	8.2	-	-	32	168	45
DIN 6319-31-C	31	-	56	-	-	M 30	3.6	11.2	-	-	41	269	100
DIN 6319-37-C	37	-	68	-	-	M 36	4.6	14	-	-	50	394	190
DIN 6319-43-C	43	-	78	-	-	M 42	6.5	17	-	-	58	542	305
DIN 6319-50-C	50	-	92	-	-	M 48	8	21	-	-	67	714	540
DIN 6319-7,1-D	-	7.1	-	12	11	M 6	-	-	2.8	4.2	9	9	2
DIN 6319-9,6-D	-	9.6	-	17	14.5	M 8	-	-	3.5	5.6	12	17	4
DIN 6319-12-D	-	12	-	21	18.5	M 10	-	-	4.2	6.5	15	26	7
DIN 6319-14,2-D	-	14.2	-	24	20	M 12	-	-	5	8	17	38	10
DIN 6319-16,5-D	-	16.5	-	28	24.8	M 14	-	-	5.6	8.5	22	53	15
DIN 6319-19-D	-	19	-	30	26	M 16	-	-	6.2	9.6	22	73	18
DIN 6319-23,2-D	-	23.2	-	36	31	M 20	-	-	7.5	11.7	27	117	30
DIN 6319-28-D	-	28	-	44	37	M 24	-	-	9.5	15.2	32	168	61
DIN 6319-35-D	-	35	-	56	49	M 30	-	-	12	19.2	41	269	120
DIN 6319-42-D	-	42	-	68	60	M 36	-	-	15	23.5	50	394	230
DIN 6319-49-D	-	49	-	78	70	M 42	-	-	18	29	58	542	360
DIN 6319-56-D	-	56	-	92	82	M 48	-	-	22	35.5	67	714	640
DIN 6319-7,1-G	-	7.1	-	17	11	M 6	-	-	4	-	9	9	6
DIN 6319-9,6-G	-	9.6	-	24	14.5	M 8	-	-	5	-	12	17	14
DIN 6319-12-G	-	12	-	30	18.5	M 10	-	-	5	-	15	26	20
DIN 6319-14,2-G	-	14.2	-	36	20	M 12	-	-	6	-	17	38	38
DIN 6319-19-G	-	19	-	44	26	M 16	-	-	7	-	22	73	50
DIN 6319-23,2-G	-	23.2	-	50	31	M 20	-	-	8	-	27	117	92
DIN 6319-28-G	-	28	-	60	37	M 24	-	-	10	-	32	168	165
DIN 6319-35-G	-	35	-	68	49	M 30	-	-	12	-	41	269	235



9

Machine elements

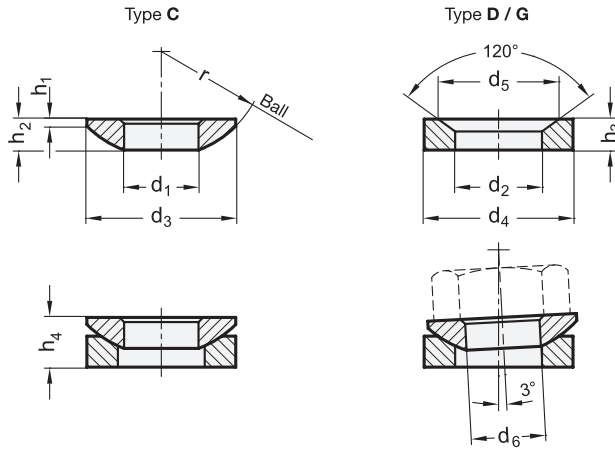

DIN 6319-NI

STAINLESS STEEL

Description	d1 H13	d2 H13	d3	d4	d5	d6	h1	h2	h3	h4	r	⚙
DIN 6319-6,4-C-NI	6.4	-	12	-	-	M 6	0.7	2.3	-	-	9	1
DIN 6319-8,4-C-NI	8.4	-	17	-	-	M 8	0.6	3.2	-	-	12	3
DIN 6319-10,5-C-NI	10.5	-	21	-	-	M 10	0.8	4	-	-	15	6
DIN 6319-13-C-NI	13	-	24	-	-	M 12	1.1	4.6	-	-	17	8
DIN 6319-17-C-NI	17	-	30	-	-	M 16	1.3	5.3	-	-	22	13
DIN 6319-21-C-NI	21	-	36	-	-	M 20	2	6.3	-	-	27	22
DIN 6319-25-C-NI	25	-	44	-	-	M 24	2.4	8.2	-	-	32	43
DIN 6319-31-C-NI	31	-	56	-	-	M 30	3.6	11.2	-	-	41	110
DIN 6319-37-C-NI	37	-	68	-	-	M 36	4.6	14	-	-	50	190
DIN 6319-43-C-NI	43	-	78	-	-	M 42	6.5	17	-	-	58	305
DIN 6319-50-C-NI	50	-	92	-	-	M 48	8	21	-	-	67	540
DIN 6319-7,1-D-NI	-	7.1	-	12	11	M 6	-	-	2.8	4.2	9	1
DIN 6319-9,6-D-NI	-	9.6	-	17	14.5	M 8	-	-	3.5	5.6	12	4
DIN 6319-12-D-NI	-	12	-	21	18.5	M 10	-	-	4.2	6.5	15	6
DIN 6319-14,2-D-NI	-	14.2	-	24	20	M 12	-	-	5	8	17	10
DIN 6319-19-D-NI	-	19	-	30	26	M 16	-	-	6.2	9.6	22	18
DIN 6319-23,2-D-NI	-	23.2	-	36	31	M 20	-	-	7.5	11.7	27	32
DIN 6319-28-D-NI	-	28	-	44	37	M 24	-	-	9.5	15.2	32	61
DIN 6319-35-D-NI	-	35	-	56	49	M 30	-	-	12	19.2	41	110
DIN 6319-42-D-NI	-	42	-	68	60	M 36	-	-	15	23.5	50	230
DIN 6319-49-D-NI	-	49	-	78	70	M 42	-	-	18	29	58	360
DIN 6319-56-D-NI	-	56	-	92	82	M 48	-	-	22	35.5	67	640

DIN 6319-A4

STAINLESS STEEL

Description	d1 H13	d2 H13	d3	d4	d5	d6	h1	h2	h3	h4	r	⚙
DIN 6319-6,4-C-A4	6.4	-	12	-	-	M 6	0.7	2.3	-	-	9	3
DIN 6319-8,4-C-A4	8.4	-	17	-	-	M 8	0.6	3.2	-	-	12	2
DIN 6319-10,5-C-A4	10.5	-	21	-	-	M 10	0.8	4	-	-	15	7
DIN 6319-13-C-A4	13	-	24	-	-	M 12	1.1	4.6	-	-	17	7
DIN 6319-17-C-A4	17	-	30	-	-	M 16	1.3	5.3	-	-	22	13
DIN 6319-21-C-A4	21	-	36	-	-	M 20	2	6.3	-	-	27	22
DIN 6319-25-C-A4	25	-	44	-	-	M 24	2.4	8.2	-	-	32	43
DIN 6319-31-C-A4	31	-	56	-	-	M 30	3.6	11.2	-	-	41	110
DIN 6319-7,1-D-A4	-	7.1	-	12	11	M 6	-	-	2.8	4.2	9	2
DIN 6319-9,6-D-A4	-	9.6	-	17	14.5	M 8	-	-	3.5	5.6	12	4
DIN 6319-12-D-A4	-	12	-	21	18.5	M 10	-	-	4.2	6.5	15	7
DIN 6319-14,2-D-A4	-	14.2	-	24	20	M 12	-	-	5	8	17	10
DIN 6319-19-D-A4	-	19	-	30	26	M 16	-	-	6.2	9.6	22	18
DIN 6319-23,2-D-A4	-	23.2	-	36	31	M 20	-	-	7.5	11.7	27	31
DIN 6319-28-D-A4	-	28	-	44	37	M 24	-	-	9.5	15.2	32	61
DIN 6319-35-D-A4	-	35	-	56	49	M 30	-	-	12	19.2	41	120