

## Lifting eye bolts (rotating)

### SPECIFICATION

#### Types

- Type **A**: without spanner
- Type **B**: with spanner

#### Ring

Steel, German Material No. 1.6541

- forged
- high-tensile tempered
- 100 % electro magnetic tensile tested to EN 1677
- plastic coated, pink

#### Bolt

Steel

Tensile strength class 10.9

100 % electro magnetic tensile tested



### INFORMATION

The lifting eye bolts GN 581 are mounted in rotating bearings, allowing the direction of the force action to be adjusted and preventing inadvertent loosening or overturning (as potentially possible in lifting eye bolts DIN 580, see page 1076).

Lifting eye bolts GN 581 offer a high load carrying capacity and they are tested to meet safety standards (safety factor 4).

The rated load carrying capacity listed in the above table is clearly marked on the ring. It applies to the most unfavourable load application of the load types listed opposite.

Lifting eye bolts GN 581 comply with Mechanical Engineering Directive 2006 / 42 / EG and are BG tested.

The integrated RFID transponder clearly marks and identifies the sling and lifting gear, e.g. during the prescribed regular inspection.

The hexagon socket bolt cannot be removed from the ring.

Type B is suitable for assembly without the need to use tools: inserting the spanner in the hexagon socket of the bolt allows the bolt to be turned in and out by hand.

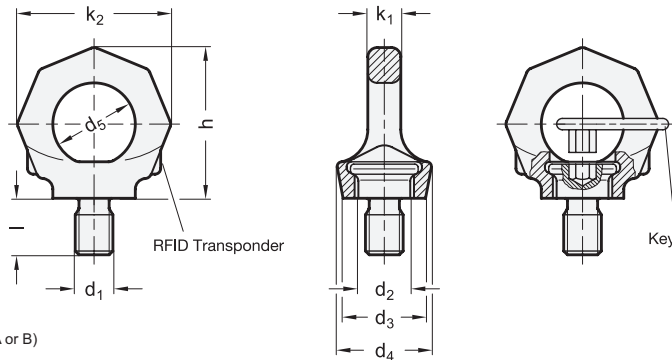

\* Complete with type index of the Lifting eye bolts (A or B)

- A** without spanner
- B** with spanner

### GN 581

Description	d1	d2	d3	d4	d5	h	k1	k2	l	Nominal load (WLL)	⚖️
GN 581-M6-*	M 6	13	23	28	20	37	7	37	9	0.1 t [1.0 kN]	100
GN 581-M8-*	M 8	16,3	25	30	25	46	9	47	12	0.3 t [3.0 kN]	120
GN 581-M10-*	M 10	16,3	25	30	25	46	9	47	15	0.4 t [4.0 kN]	120
GN 581-M12-*	M 12	19,8	30	34	30	55	10	56	18	0.75 t [7.5 kN]	180
GN 581-M16-*	M 16	23,5	36	40	35	64	13	65	24	1.5 t [15.0 kN]	320
GN 581-M20-*	M 20	29,3	41	50	40	75	16	76	30	2.3 t [23.0 kN]	490
GN 581-M24-*	M 24	35	51	60	49	90	19	92	36	3.2 t [32.0 kN]	900
GN 581-M30-*	M 30	44	66	75	60	113	24	114	45	4.5 t [45.0 kN]	1650
GN 581-M36-*	M 36	53	76	98	73	135	29	135	54	7.0 t [70.0 kN]	3100

Weight A



Method of mounting										
<b>Number</b>	1	1	2	2	2	2	2	3 and 4	3 and 4	3 and 4
<b>Angles of inclination</b>	0°	90°	0°	90°	0° to 45°	45° to 60°	asymm.	0° to 45°	45° to 60°	asymm.
<b>Factor</b>		1		2	1.4	1	1	2.1	1.5	1
<b>M 6</b>	0.50	0.10 t	1.00	0.20 t	0.14	0.10 t	0.10 t	0.21 t	0.15 t	0.10t
<b>M 8</b>	1.00 [0.14]	0.30 t	2.00 [0.28]	0.60 t	0.42 [0.10]	0.30 t	0.30 t	0.63 t	0.45 t	0.30 t
<b>M 10</b>	1.00 t [0.23]	0.40 t	2.00 [0.46]	0.80 t	0.56 [0.17]	0.40 t	0.40 t	0.84 t	0.60 t	0.40 t
<b>M 12</b>	2.00 [0.34]	0.75 t	4.00 [0.68]	1.50 t	1.00 [0.24]	0.75 t	0.75 t	1.57 t	1.12 t	0.75 t
<b>M 16</b>	4.00 [0.70]	1.50 t	8.00 [1.40]	3.00 t	2.12 [0.50]	1.50 t	1.50 t	3.15 t	2.24 t	1.50 t
<b>M 20</b>	6.00 [1.20]	2.30 t	12.00 [2.40]	4.60 t	3.22 [0.86]	2.30 t	2.30 t	4.83 t	3.45 t	2.30 t
<b>M 24</b>	8.00 [1.80]	3.20 t	16.00 [3.60]	6.40 t	4.50 [1.29]	3.20 t	3.20 t	6.70 t	4.80 t	3.20 t
<b>M 30</b>	12.00 [3.20]	4.50 t	24.00 [6.40]	9.00 t	6.30 [2.30]	4.50 t	4.50 t	9.50 t	6.75 t	4.50 t
<b>M 36</b>	16.0 [4.60]	7.00 t	32.00 [9.20]	14.00 t	9.80 [3.30]	7.00 t	7.00 t	14.70 t	10.50 t	7.00 t

**SAFETY INSTRUCTIONS**

The loads given in brackets refer to the load capacity of the corresponding lifting eye bolt DIN 580. If such a value is not indicated the use of the lifting eye bolts DIN 580 is not permitted!

The bolt-on surface for the lifting eye bolts GN 581 must be plane and at a right angle to the threaded borehole; the countersinking must be ≤ the nominal diameter of the thread.

Screwed in, the collar of the screw must make firm contact (do not use washers) and the eye bolt must rotate freely by 360°.

Before applying the load, turn the lifting eye bolt in the direction of the force. The lifting eye bolt is not suitable for frequent rotation cycles under load.

The specified load values apply for a minimum screw-in length of 1.5 × nominal thread diameter in steel with a minimum tensile strength of 37 kp/mm<sup>2</sup>, at an ambient temperature of - 40° C to + 280° C. Load-bearing capacity under different conditions upon request. Operating instructions with more details and specifications are included with every delivery (see also www.lesa-ganter.com).