

- 1
- 2
- 3
- 4
- 5
- 6
- 7
- 8
- 9
- 10
- 11
- 12
- 13
- 14
- 15

BASE

Glass-fibre reinforced polyamide based (PA) technopolymer, black colour, matte finish.

ARTICULATED STEM

Threaded zinc-plated steel with regulation hexagon.

STANDARD EXECUTIONS

- **LS.A:** without no-slip disk.
- **LS.A-AS:** with NBR rubber no-slip disk, hardness 70 Shore A, supplied assembled to the base.

FEATURES

The particular assembling system of the no-slip disk to the base assures a perfect anchoring, preventing separation even in case of impact during transport or of adhesion (sticking) to the floor (see No-slip disks on page 979).

ORDER INFORMATION

The levelling elements are supplied unassembled to make carriage and storage easier. The components (base and stem) are supplied in separate packing: less volume taken and better protection from scratches and dirt.

To order bases and stems separately, see:

- table of possible combinations Bases/Stems (see page 984)
- the codes of the Bases (see page 980)
- the codes of the Stems (see page 986).

ACCESSORIES ON REQUEST

Zinc-plated steel nut (see Nuts NT. on page 979).

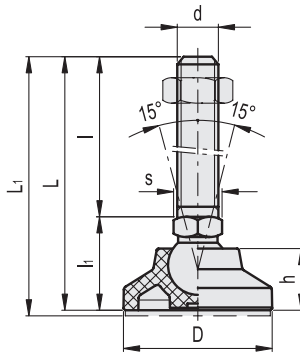

Conversion Table	
1 mm = 0.039 inch	
D	
mm	inch
25	0.98
32	1.26
40	1.57
50	1.97

LS.A

LS.A-AS

METRIC

Code	Description	Code	Description	D	d	L	Lf#	l	lt	h	s	Articulation ∅	Max. limit static load* [N]	△	△	#
341121	LS.A-25-14-M8x43	346121	LS.A-25-14-AS-M8x43	25	M8	67	70	43	24	12	14	14	5000	32	34	
341125	LS.A-25-14-M8x68	346125	LS.A-25-14-AS-M8x68	25	M8	92	95	68	24	12	14	14	5000	42	44	
341221	LS.A-25-14-M10x43	346221	LS.A-25-14-AS-M10x43	25	M10	67	70	43	24	12	14	14	5000	42	44	
341225	LS.A-25-14-M10x68	346225	LS.A-25-14-AS-M10x68	25	M10	92	95	68	24	12	14	14	5000	54	56	
341231	LS.A-25-14-M10x98	346231	LS.A-25-14-AS-M10x98	25	M10	122	125	98	24	12	14	14	5000	68	70	
341321	LS.A-25-14-M12x43	346321	LS.A-25-14-AS-M12x43	25	M12	67	70	43	24	12	14	14	5000	52	54	
341325	LS.A-25-14-M12x68	346325	LS.A-25-14-AS-M12x68	25	M12	92	95	68	24	12	14	14	5000	69	71	
341331	LS.A-25-14-M12x98	346331	LS.A-25-14-AS-M12x98	25	M12	122	125	98	24	12	14	14	5000	90	92	
341421	LS.A-25-14-M14X68	346421	LS.A-25-14-AS-M14X68	25	M14	92	95	68	24	12	14	14	5000	84	86	
341431	LS.A-25-14-M14X98	346431	LS.A-25-14-AS-M14X98	25	M14	122	125	98	24	12	14	14	5000	105	107	
341441	LS.A-25-14-M14X148	346441	LS.A-25-14-AS-M14X148	25	M14	172	175	148	24	12	14	14	5000	188	190	
341521	LS.A-25-14-M16x68	346521	LS.A-25-14-AS-M16x68	25	M16	92	95	68	24	12	16	14	5000	113	115	
341525	LS.A-25-14-M16x108	346525	LS.A-25-14-AS-M16x108	25	M16	132	135	108	24	12	16	14	5000	162	164	
341541	LS.A-25-14-M16x148	346541	LS.A-25-14-AS-M16x148	25	M16	172	175	148	24	12	16	14	5000	214	216	
341561	LS.A-25-14-M16x168	346561	LS.A-25-14-AS-M16x168	25	M16	192	195	168	24	12	16	14	5000	240	242	

* The max static load is the value above which the load applied to the element may cause some plastic material breakage, in particular conditions of use. Obviously, a factor that takes into consideration the importance and the safety level of the specific application must be applied to this value.

Data with no-slip disk mounted.

Conversion Table	
1 mm = 0.039 inch	
D	
mm	inch
25	0.98
32	1.26
40	1.57
50	1.97

LS.A		LS.A-AS		METRIC											
Code	Description	Code	Description	D	d	L	L#	l	l1	h	s	Articulation ∅	Max. limit static load* [N]	⚖	⚖ #
342121	LS.A-32-14-M8x43	347121	LS.A-32-14-AS-M8x43	32	M8	68	71	43	25	15	14	14	7000	37	41
342125	LS.A-32-14-M8x68	347125	LS.A-32-14-AS-M8x68	32	M8	93	96	68	25	15	14	14	7000	47	51
342221	LS.A-32-14-M10x43	347221	LS.A-32-14-AS-M10x43	32	M10	68	71	43	25	15	14	14	7000	47	51
342225	LS.A-32-14-M10x68	347225	LS.A-32-14-AS-M10x68	32	M10	93	96	68	25	15	14	14	7000	59	63
342231	LS.A-32-14-M10x98	347231	LS.A-32-14-AS-M10x98	32	M10	123	126	98	25	15	14	14	7000	73	77
342321	LS.A-32-14-M12x43	347321	LS.A-32-14-AS-M12x43	32	M12	68	71	43	25	15	14	14	7000	57	61
342325	LS.A-32-14-M12x68	347325	LS.A-32-14-AS-M12x68	32	M12	93	96	68	25	15	14	14	7000	74	78
342331	LS.A-32-14-M12x98	347331	LS.A-32-14-AS-M12x98	32	M12	123	126	98	25	15	14	14	7000	95	99
342421	LS.A-32-14-M14X68	347421	LS.A-32-14-AS-M14X68	32	M14	93	96	68	25	15	14	14	7000	90	94
342431	LS.A-32-14-M14X98	347431	LS.A-32-14-AS-M14X98	32	M14	123	126	98	25	15	14	14	7000	111	115
342441	LS.A-32-14-M14X148	347441	LS.A-32-14-AS-M14X148	32	M14	173	176	148	25	15	14	14	7000	194	198
342521	LS.A-32-14-M16x68	347521	LS.A-32-14-AS-M16x68	32	M16	93	96	68	25	15	16	14	7000	118	122
342525	LS.A-32-14-M16x108	347525	LS.A-32-14-AS-M16x108	32	M16	133	136	108	25	15	16	14	7000	170	174
342541	LS.A-32-14-M16x148	347541	LS.A-32-14-AS-M16x148	32	M16	173	176	148	25	15	16	14	7000	222	226
342561	LS.A-32-14-M16x168	347561	LS.A-32-14-AS-M16x168	32	M16	193	196	168	25	15	16	14	7000	248	252
343121	LS.A-40-14-M8x43	348121	LS.A-40-14-AS-M8x43	40	M8	68	71	43	25	17	14	14	10000	41	48
343125	LS.A-40-14-M8x68	348125	LS.A-40-14-AS-M8x68	40	M8	93	96	68	25	17	14	14	10000	51	58
343221	LS.A-40-14-M10x43	348221	LS.A-40-14-AS-M10x43	40	M10	68	71	43	25	17	14	14	10000	51	58
343225	LS.A-40-14-M10x68	348225	LS.A-40-14-AS-M10x68	40	M10	93	96	68	25	17	14	14	10000	63	70
343231	LS.A-40-14-M10x98	348231	LS.A-40-14-AS-M10x98	40	M10	123	126	98	25	17	14	14	10000	77	84
343321	LS.A-40-14-M12x43	348321	LS.A-40-14-AS-M12x43	40	M12	68	71	43	25	17	14	14	10000	61	68
343325	LS.A-40-14-M12x68	348325	LS.A-40-14-AS-M12x68	40	M12	93	96	68	25	17	14	14	10000	78	85
343331	LS.A-40-14-M12x98	348331	LS.A-40-14-AS-M12x98	40	M12	123	126	98	25	17	14	14	10000	99	106
343421	LS.A-40-14-M14X68	348421	LS.A-40-14-AS-M14X68	40	M14	93	96	68	25	17	14	14	10000	93	100
343431	LS.A-40-14-M14X98	348431	LS.A-40-14-AS-M14X98	40	M14	123	126	98	25	17	14	14	10000	114	121
343441	LS.A-40-14-M14X148	348441	LS.A-40-14-AS-M14X148	40	M14	173	176	148	25	17	14	14	10000	197	204
343521	LS.A-40-14-M16x68	348521	LS.A-40-14-AS-M16x68	40	M16	93	96	68	25	17	16	14	10000	122	129
343525	LS.A-40-14-M16x108	348525	LS.A-40-14-AS-M16x108	40	M16	133	136	108	25	17	16	14	10000	174	181
343541	LS.A-40-14-M16x148	348541	LS.A-40-14-AS-M16x148	40	M16	173	176	148	25	17	16	14	10000	226	233
343561	LS.A-40-14-M16x168	348561	LS.A-40-14-AS-M16x168	40	M16	193	196	168	25	17	16	14	10000	252	259
344121	LS.A-50-14-M8x43	349121	LS.A-50-14-AS-M8x43	50	M8	70	73	43	27	19	14	14	10000	48	60
344125	LS.A-50-14-M8x68	349125	LS.A-50-14-AS-M8x68	50	M8	95	98	68	27	19	14	14	10000	58	70
344221	LS.A-50-14-M10x43	349221	LS.A-50-14-AS-M10x43	50	M10	70	73	43	27	19	14	14	10000	58	70
344225	LS.A-50-14-M10x68	349225	LS.A-50-14-AS-M10x68	50	M10	95	98	68	27	19	14	14	10000	70	82
344231	LS.A-50-14-M10x98	349231	LS.A-50-14-AS-M10x98	50	M10	125	128	98	27	19	14	14	10000	84	96
344321	LS.A-50-14-M12x43	349321	LS.A-50-14-AS-M12x43	50	M12	70	73	43	27	19	14	14	10000	68	80
344325	LS.A-50-14-M12x68	349325	LS.A-50-14-AS-M12x68	50	M12	95	98	68	27	19	14	14	10000	85	97
344331	LS.A-50-14-M12x98	349331	LS.A-50-14-AS-M12x98	50	M12	125	128	98	27	19	14	14	10000	106	118
344421	LS.A-50-14-M14X68	349421	LS.A-50-14-AS-M14X68	50	M14	95	98	68	27	19	14	14	10000	100	112
344431	LS.A-50-14-M14X98	349431	LS.A-50-14-AS-M14X98	50	M14	125	128	98	27	19	14	14	10000	121	133
344441	LS.A-50-14-M14X148	349441	LS.A-50-14-AS-M14X148	50	M14	175	178	148	27	19	14	14	10000	204	216
344521	LS.A-50-14-M16x68	349521	LS.A-50-14-AS-M16x68	50	M16	95	98	68	27	19	16	14	10000	129	141
344525	LS.A-50-14-M16x108	349525	LS.A-50-14-AS-M16x108	50	M16	135	138	108	27	19	16	14	10000	181	193
344541	LS.A-50-14-M16x148	349541	LS.A-50-14-AS-M16x148	50	M16	175	178	148	27	19	16	14	10000	233	245
344561	LS.A-50-14-M16x168	349561	LS.A-50-14-AS-M16x168	50	M16	195	198	168	27	19	16	14	10000	259	271

* The max static load is the value above which the load applied to the element may cause some plastic material breakage, in particular conditions of use. Obviously, a factor that takes into consideration the importance and the safety level of the specific application must be applied to this value.

Data with no-slip disk mounted.



Levelling elements and supports