

## Ball transfer units

Heavy duty Stainless Steel / Steel housing, with collar

### SPECIFICATION

Housing Steel **SBL**

- turned
- zinc plated, blue passivated
- Ball Steel, blank

Housing Steel **SNI**

- turned
- zinc plated, blue passivated
- Ball Stainless Steel AISI 420C

Housing Stainless Steel **NNI**

- AISI 420B
- AISI 303 (only size 15)
- Ball Stainless Steel AISI 420C

### INFORMATION

Ball transfer units GN 509.1 are used on conveyer tracks. They assist a linear or rotary movement of heavy loads on a conveyer track.

### ON REQUEST

- Plastic ball (Polyamide)

### ACCESSORY

- Spring rings GN 509.3 (see page 1099)

### TECHNICAL INFORMATION

- Stainless Steel characteristics (see page A26)

All ball operated conveyers are made up of a number of balls each located in a socket resting on a number of smaller support balls thus allowing the larger ball to rotate in any direction.

#### Arrangement and choice of ball size

When deciding on the size of the conveyer the following factors have to be taken into account: Weight, size, base material as well as the load to be carried.

The **max. distance between the roller balls „a<sub>2</sub>“** (on a plane surface) is arrived at by dividing the shortest edge length of the load to be conveyed by 2.5. This ensures that a load will always be supported by carrier balls thus preventing it from tipping over into an empty space.

The required **load carrying capacity** of the balls is determined by the weight of the actual load divided by three. This is arrived at from the assumption that, due to tolerances on the load carrying face and the spacing of the balls in general, only three balls will be under load at any one time.

- a<sub>1</sub> = shortest edge length of the load      F<sub>1</sub> = Load weight
- a<sub>2</sub> = max. distance between roller balls      F<sub>2</sub> = Load per roller ball
- a<sub>2</sub> = a<sub>1</sub>/2.5      F<sub>2</sub> = F<sub>1</sub>/3

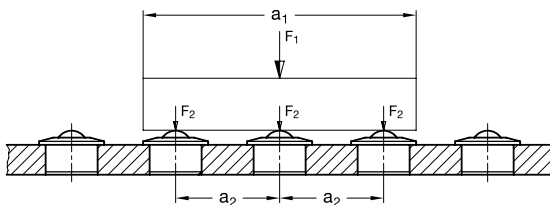

### Speed and friction

The permissible conveying speed is 2 m/sec. With larger roller balls at speeds exceeding 1 m/sec., depending on the weight being conveyed, an increased temperature would be expected.

The **friction values** of the balls at a speed of 1 m/sec. will be in the region of 0.005 μ. This value is, however, dependent on application of usage and could be subject to large variations.

In comparison of balls with sheet metal housings (GN 509, see page 1100) with balls in heavy duty steel housing GN 509.1, the latter have a higher rigidity. Hence the static values of balls in steel housing can be applied.

**Lubrication** to prevent corrosion is recommended. The general recommendations applicable to ordinary roller bearings will be sufficient. In most applications lubrication can be ignored.

### Resistance to temperature

Balls from size 36 upwards are fitted with a felt seal as protection against ingress of dirt and dust. The latter have a max temperature of 100 °C only.

Balls without the felt seal can also be used at higher operating temperatures. This, however, will lead to a reduced conveying capacity (c). The following table gives indicative values:

- 125 °C ./ .10 %
- 150 °C ./ .20 %
- 170 °C ./ .30 %
- 200 °C ./ .50 %

The max. operating temperatur for ball transfer units with plastic ball is 60 °C.

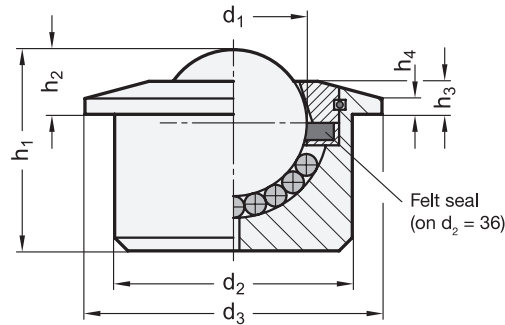

GN 509.1

STAINLESS STEEL

Description	Size	d1	d2 ±0.08	d3	h1 ±0.3	h2 ±0.3	h3 ±0.3	h4	Load C in N	⚖️
GN 509.1-12-SBL	12	12.7	22	27	17	8	4	3.2	200	35
GN 509.1-15-SBL	15	15.8	24	30	20	8.1	3.5	1	500	44
GN 509.1-22-SBL	22	22.2	36	45	30.5	9.8	5	2.4	1300	186
GN 509.1-30-SBL	30	30.1	45	55	36.8	13.8	7	4.5	2500	360
GN 509.1-45-SBL	45	44.4	62	75	53.5	19	9.5	5.5	6000	980
GN 509.1-60-SBL	60	60	100	117	77.5	30	15	10	13000	3700
GN 509.1-12-SNI	12	12.7	22	27	17	8	4	3.2	150	35
GN 509.1-15-SNI	15	15.8	24	30	20	8.1	3.5	1	400	50
GN 509.1-22-SNI	22	22.2	36	45	30.5	9.8	5	2.4	1000	180
GN 509.1-30-SNI	30	30.1	45	55	36.8	13.8	7	4.5	2000	360
GN 509.1-45-SNI	45	44.4	62	75	53.5	19	9.5	5.5	4500	980
GN 509.1-60-SNI	60	60	100	117	77.5	30	15	10	10000	3700
GN 509.1-12-NNI	12	12.7	22	27	17	8	4	3.2	150	35
GN 509.1-15-NNI	15	15.8	24	30	20	8.1	3.5	1	400	55
GN 509.1-22-NNI	22	22.2	36	45	30.5	9.8	5	2.4	1000	193
GN 509.1-30-NNI	30	30.1	45	55	36.8	13.8	7	4.5	2000	360
GN 509.1-45-NNI	45	44.4	62	75	53.5	19	9.5	5.5	4500	980
GN 509.1-60-NNI	60	60	100	117	77.5	30	15	10	10000	3700

