

Clamp mounts

for toggle clamps with solid clamping arm

SPECIFICATION

Steel
zinc plated, blue passivated

INFORMATION

GN 809 clamp mounts for toggle clamp spindle assemblies have been developed for various toggle clamps in the design version "solid clamping arm".

The clamp mounts can be moved along the clamping arm and be adjusted in height. Once the desired position is reached, fix the mounting in place with the clamping screw.

The thread d_2 serves to hold the wide variety of clamping bolts, spring elements and similar devices.

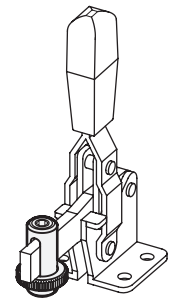
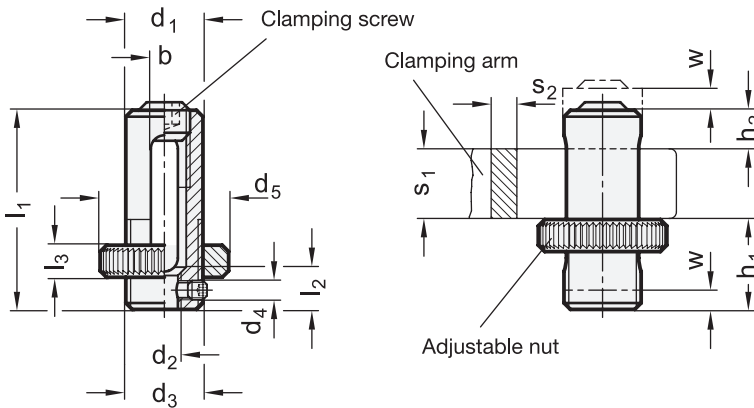

GN 809

Description	d1	d2	b	d3	d4	d5	h1 max.	h2			l1	l2	l3	s1	s2 w	For toggle clamps					
								min.	max.	min.						GN 860	GN 810.1	GN 820	GN 812		
																GN 862	GN 820.1	GN 820.3	GN 812.1	GN 820.4	
GN 809-12-M5	12	M 5	4.2	M 12 x 1.5	M 3	20	14	8	12	6	31	6	5	11	4	3	70	75	75	-	22
GN 809-16-M6	16	M 6	5.3	M 16 x 1.5	M 4	22	16 (18)*	10	16	8	40	10	5.5	16 (14)*	5	4	125	130	130	-	43
GN 809-18-M8	18	M 8	6.3	M 18 x 1.5	M 4	24	23 (24)**	13	20	10	51	13	6	18 (17)**	6	5	200	230	230	200	65
GN 809-20-M8	20	M 8	7.3	M 20 x 1.5	M 5	27	25	15	20	10	57	15	7	22	7	5	-	330	355	-	96
GN 809-22-M10	22	M 10	8.3	M 22 x 1.5	M 5	30	28	16	24	12	60	16	8	20	8	5	300	-	-	300	121

* Dimension in (...) applies only to GN 860 | ** Dimension in (...) applies only to GN 812, GN 812.1, GN 862 and GN 862.1