

INCH-POUND

MS51830F
 21 June 2012
 SUPERSEDING
 MS51830E
 9 March 1992

DETAIL SPECIFICATION SHEET

INSERT, SCREW – THREAD, LOCKED IN, KEY-LOCKED,
 MINIATURE AND LIGHTWEIGHT

This specification is approved for use by all Departments and Agencies of the Department of Defense.

The requirements for acquiring the product described herein shall consist of this specification sheet and procurement specification MIL-I-45914.

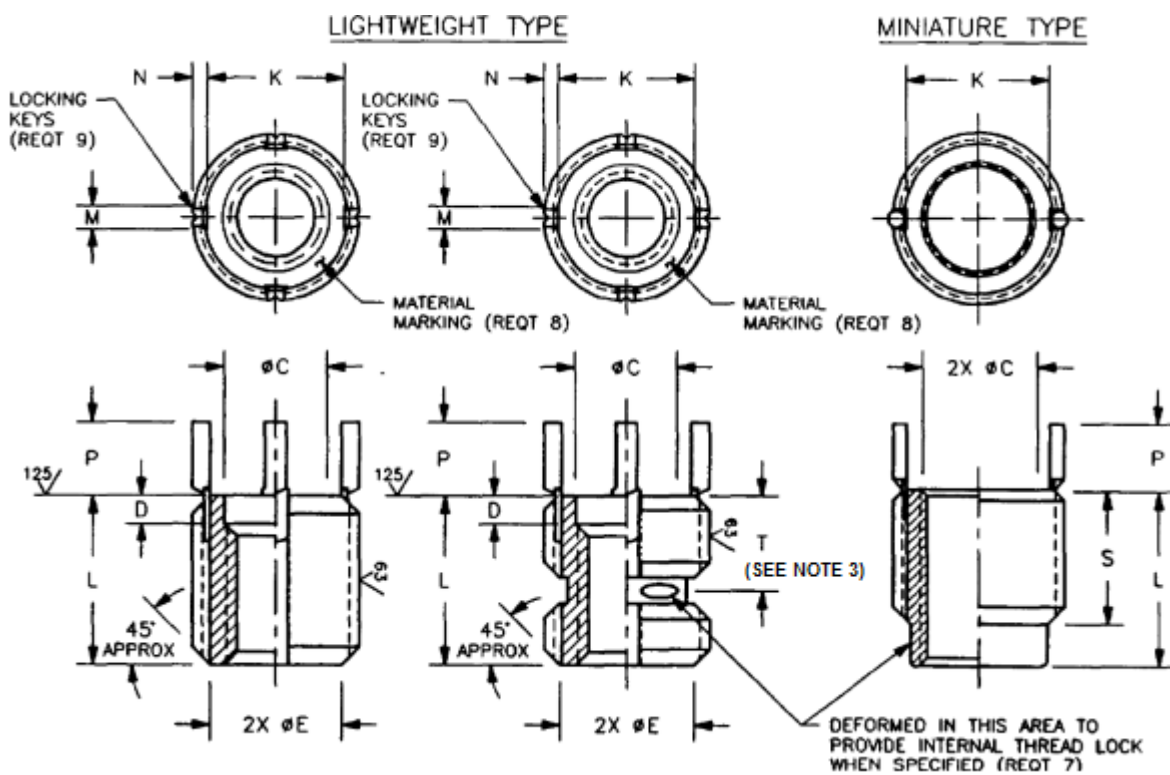

FIGURE 1. INSERT, COURSE INTERNAL THREADS.

MS51830F

TABLE I. COURSE INTERNAL THREADS.

| DASH NO. | INTERNAL THREAD SAE AS8879 UNJC-3B | EXTERNAL THREAD FED-STD-H28/2 EXCEPT MODIFIED MINOR DIA. | | ØC ±.005 | D ±.010 | ØE REF | K REF | L ±.015 | KEY DIMENSIONS | | | S ±.010 | T ±.030 |
|----------|--|--|--------------|-------------|------------|-----------|----------|------------|----------------|-------|-------|------------|------------|
| | | SIZE | MINOR DIA | | | | | | M REF | N REF | P REF | | |
| 101 | .086-56 | .164-32UNC-2A | .127 .124 | .089 | --- | --- | .109 | .120 | --- | --- | .060 | .090 | --- |
| 102 | .112-40 | .190-28UNF-2A | .153 .150 | .114 | --- | --- | .134 | .170 | --- | --- | .080 | .125 | --- |
| 103 | .138-32 | .216-28UNF-2A | .174 .171 | .141 | --- | --- | .160 | .170 | --- | --- | .080 | .125 | --- |
| 104 | .164-32 | .250-28UNF-2A | .215 .212 | .169 | --- | --- | .196 | .220 | --- | --- | .100 | .175 | --- |
| 105 | .190-24 | .3125-18UNC-2A | .256 .249 | .196 | .070 | .250 | .220 | .312 | .068 | .040 | .160 | --- | .220 |
| 106 | .250-20 | .375-16UNC-2A | .320 .312 | .257 | .070 | .310 | .284 | .375 | .068 | .040 | .190 | --- | .220 |
| 107 | .3125-18 | .4375-14UNC-2A | .383 .375 | .316 | .070 | .375 | .345 | .437 | .068 | .040 | .190 | --- | .220 |
| 108 | .375-16 | .500-13UNC-2A | .440 .432 | .380 | .070 | .430 | .407 | .500 | .068 | .040 | .190 | --- | .240 |
| 109 | .4375-14 | .5625-12UNC-2A | .503 .495 | .445 | .070 | .495 | .469 | .562 | .068 | .040 | .190 | --- | .270 |
| 110 | .500-13 | .625-11UNC-2A | .565 .551 | .507 | .070 | .550 | .532 | .625 | .068 | .040 | .190 | --- | .280 |

MS51830F

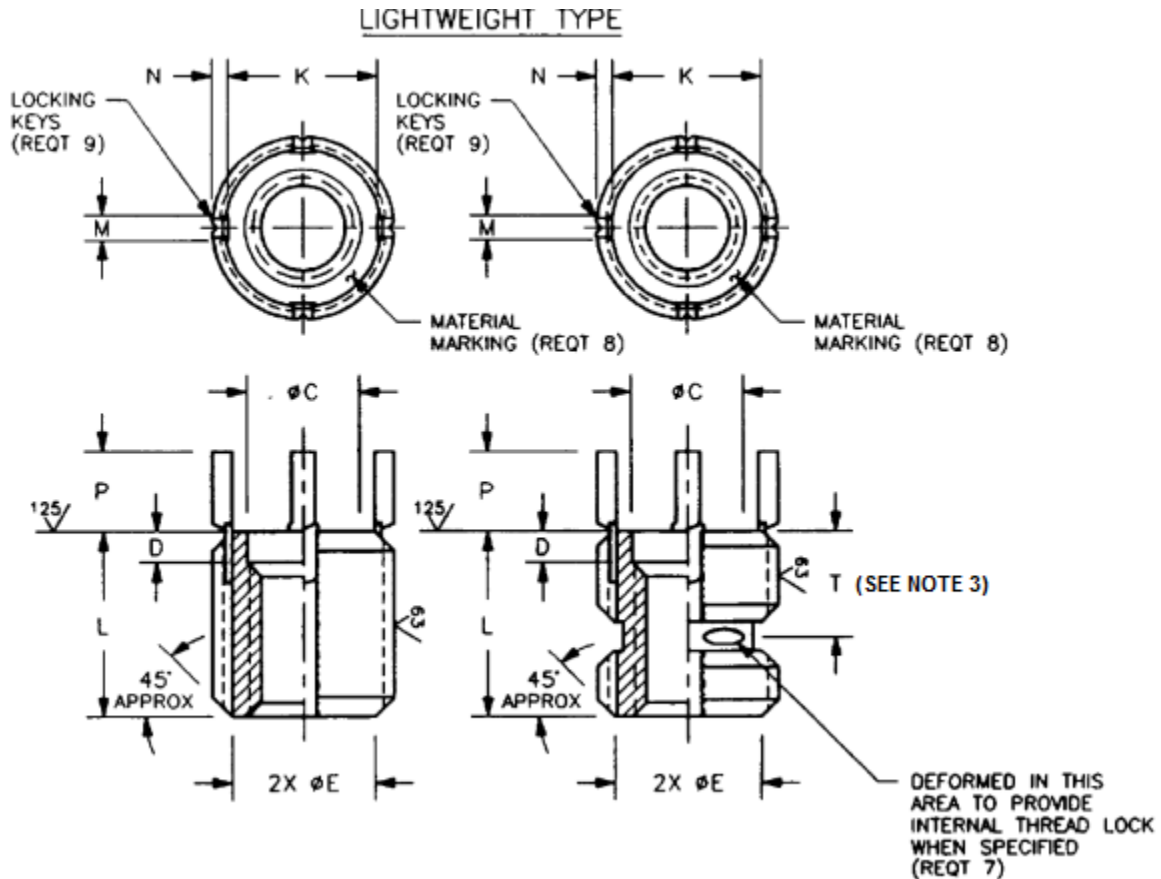

FIGURE 2. INSERT, FINE INTERNAL THREADS.

TABLE II. FINE INTERNAL THREADS.

| DASH NO. | INTERNAL THREAD SAE AS8879 UNJF-3B | EXTERNAL THREAD FED-STD-H28/2 EXCEPT MODIFIED MINOR DIA. | | ϕC | D | ϕE | K | L | KEY DIMENSIONS | | | T |
|----------|--|---|--------------|----------|------|----------|------|------|----------------|-------|-------|------|
| | | SIZE | MINOR DIA | | | | | | M REF | N REF | P REF | |
| 201 | .190-32 | .3125-18UNC-2A | .256 .249 | .196 | .070 | .250 | .220 | .312 | .068 | .040 | .160 | .220 |
| 202 | .250-28 | .375-16UNC-2A | .320 .312 | .257 | .070 | .310 | .284 | .375 | .068 | .040 | .190 | .220 |
| 203 | .3125-24 | .4375-14UNC-2A | .383 .375 | .316 | .070 | .375 | .345 | .437 | .068 | .040 | .190 | .220 |
| 204 | .375-24 | .500-13UNC-2A | .440 .432 | .380 | .070 | .430 | .407 | .500 | .068 | .040 | .190 | .240 |
| 205 | .4375-20 | .5625-12 UNC-2A | .503 .495 | .445 | .070 | .495 | .469 | .562 | .068 | .040 | .190 | .270 |
| 206 | .500-20 | .625-11 UNC-2A | .565 .551 | .507 | .070 | .550 | .532 | .625 | .068 | .040 | .190 | .280 |

MS51830F

Requirements:

1. Material. Steel, corrosion-resistant, Type 303 (UNS S30300) in accordance with chemical composition of SAE AMS 5640 (Type 1) or ASTM A582/A582M or Type 303SE (UNS S30323) in accordance with chemical composition of SAE AMS 5640 (Type 2), SAE AMS 5738 or ASTM A582/A582M.

Steel, corrosion-resistant. Type A286 (UNS S66286) in accordance with SAE AMS 5731, SAE AMS 5734 or SAE AMS 5737.

Steel, alloy, grade 4140 (UNS G41400) in accordance with SAE AMS 6349 or SAE AMS 6382 or grade 8740 (UNS G87400) in accordance with SAE AMS 6322.

Locking keys: steel, corrosion-resistant. Type 302 chemical composition of ASTM A580/A580M only.

2. Cadmium plating and surface treatment. Corrosion-resistant steel shall be passivated in accordance with SAE AMS2700. Alloy steel shall be cadmium plated in accordance with SAE AMS-QQ-P-416, Type II, Class 3. The locking keys may or may not be cadmium plated.
3. Lubrication. Inserts with self-locking internal threads shall be dry film lubricated in accordance with MIL-PRF-46010, Type I. The locking keys may or may not be lubricated.
4. Surface texture: Machined surfaces shall be in accordance with ASME B46.1.
5. Heat treatment: Alloy steel inserts shall be heat treated to 160,000 psi Ft_u minimum in accordance with SAE AMS-H- 6875. Corrosion-resistant steel inserts, type A286 (SAE AMS 5734). Shall be heat treated to 140,000 psi Ft_u minimum.
6. Hardness. Alloy steel inserts shall have a hardness range of 36-40 HRC.
7. Part number. The part number shall consist of the basic MS sheet number plus the dash number taken from Table I or Table II, as applicable:

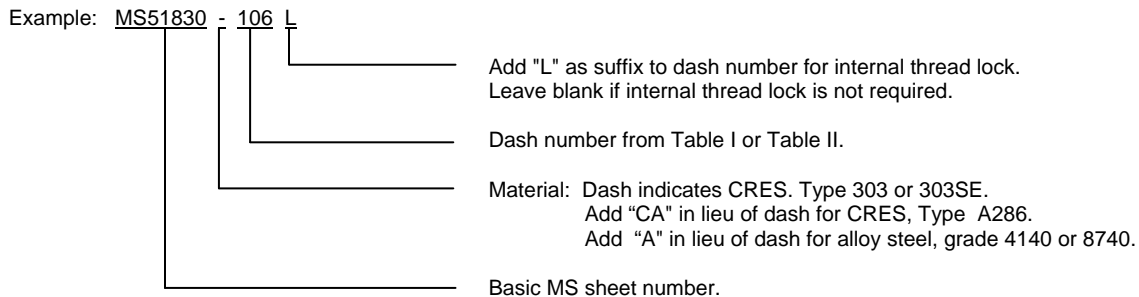

Example: MS51830CA106L indicates -Insert, Screw-Thread, Locked In, Key-Locked, Lightweight, CRES A286, .250-20UNJC-3B internal thread with internal thread lock feature.

8. Material marking: CRES 303 or 303SE has no identifying mark.
CRES A286 shall be identified on top of insert by one (1) line or dash mark.
Alloy steel 4140 or 8740 shall be identified on top of insert by two (2) parallel lines or dash marks.
Material marking of miniature type optional.
9. Inserts with internal thread size .250 and smaller shall be supplied with two (2) locking keys spaced 180° apart.
Inserts with internal thread size .3125 and greater shall be supplied with four (4) locking keys spaced 90° apart.
10. Inserts shall be free of all hanging burrs and slivers which might become dislodged under usage.
11. Source identification mark: Source identification mark shall be in accordance with MIL-I-45914.
12. All dimensions are after cadmium plating or surface treatment and prior to the addition of the lubrication.
13. Fillets are R .015 maximum.

MS51830F

Notes:

1. All dimensions are in inches.
2. Installation of inserts shall be in accordance with MS51835.
3. Distance to center of internal thread lock.
4. In the event of a conflict between the text of this standard and the references cited herein, the text of this standard shall take precedence.
5. CHANGES FROM PREVIOUS ISSUE. Marginal notations are not used in this revision to identify changes with respect to the previous issue due to the extent of the changes.

MILITARY INTEREST

Custodians:

Army - AR
Navy - AS
Air Force - 99

Preparing activity:

DLA - IS

(Project 5325-2012-011)

NOTE: The activities listed above were interested in this document as of the date of this document. Since organizations and responsibilities can change, you should verify the currency of the information above using the ASSIST Online database at <https://assist.dla.mil>.

INCH-POUND

MS51831G
 14 August 2012
 SUPERSEDING
 MS51831F
 9 March 1992

DETAIL SPECIFICATION SHEET

INSERT, SCREW – THREAD, LOCKED IN, KEY LOCKED,
 HEAVY DUTY

This specification is approved for use by all Departments and Agencies of the Department of Defense.

The requirements for acquiring the product described herein shall consist of this specification sheet and procurement specification MIL-I-45914.

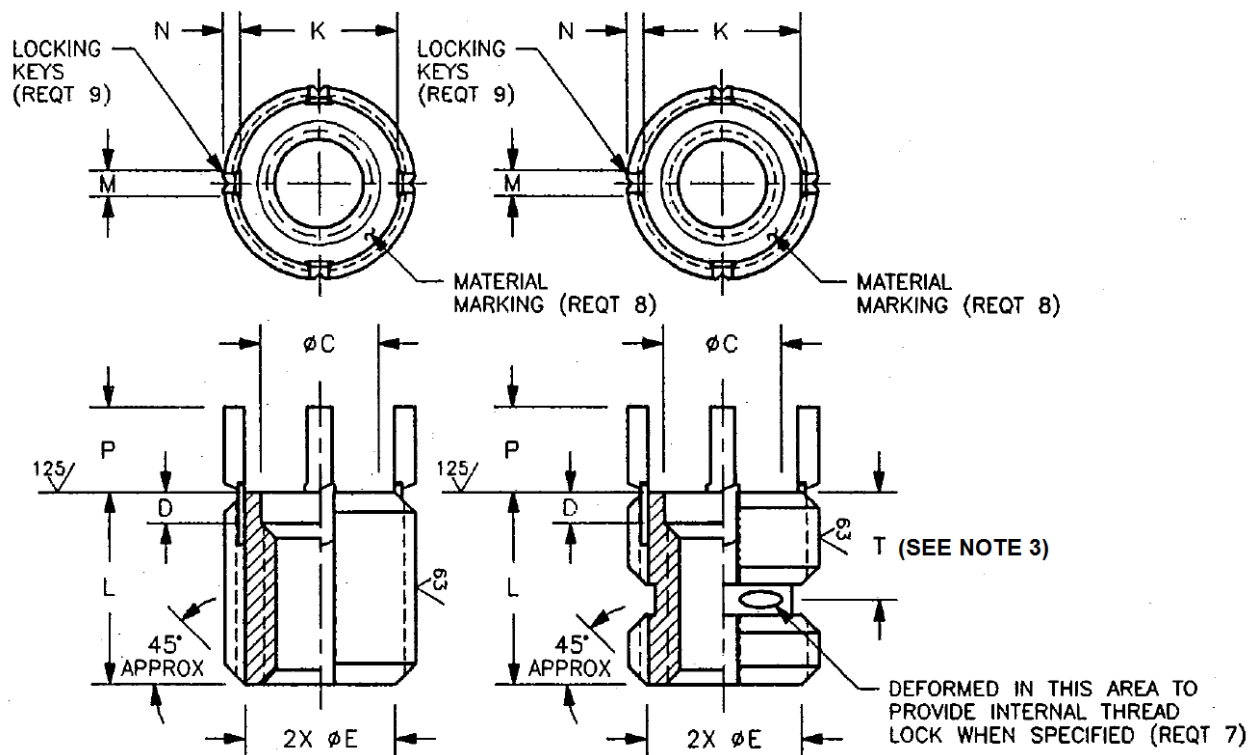

FIGURE 1. INSERT, COARSE INTERNAL THREADS.

MS51831G

TABLE I. COARSE INTERNAL THREADS.

| DASH NO. | INTERNAL THREAD SAE AS8879 UNJC-3B | EXTERNAL THREAD FED-STD-H28/2 EXCEPT MODIFIED MINOR DIA. | | ØC ±.005 | D ±.010 | ØE REF | K REF | L ±.015 | KEY DIMENSIONS | | | T ±.030 |
|----------|--|---|----------------|-------------|------------|-----------|----------|------------|----------------|----------|----------|------------|
| | | SIZE | MINOR DIA | | | | | | M REF | N REF | P REF | |
| 101 | .190-24 | .375-16UNC-2A | .320 .312 | .196 | .070 | .310 | .284 | .312 | .068 | .040 | .130 | .220 |
| 102 | .250-20 | .4375-14UNC-2A | .383 .375 | .257 | .070 | .375 | .344 | .375 | .068 | .040 | .190 | .220 |
| 103 | .3125-18 | .500-13UNC-2A | .440 .432 | .316 | .070 | .430 | .407 | .437 | .068 | .040 | .190 | .220 |
| 104 | .375-16 | .5625-12UNC-2A | .503 .495 | .380 | .070 | .495 | .469 | .500 | .068 | .040 | .190 | .250 |
| 105 | .4375-14 | .625-11UNC-2A | .565 .551 | .445 | .100 | .550 | .532 | .625 | .068 | .040 | .190 | .280 |
| 106 | .500-13 | .6875-11NS-2A | .625 .615 | .507 | .100 | .615 | .595 | .688 | .068 | .040 | .190 | .280 |
| 107 | .5625-12 | .8125-16UN-2A | .752 .744 | .580 | .100 | .745 | .720 | .812 | .068 | .040 | .190 | .320 |
| 108 | .625-11 | .875-14UNF-2A | .815 .807 | .640 | .100 | .805 | .782 | .875 | .068 | .040 | .190 | .330 |
| 109 | .750-10 | 1.125-12UNF-2A | 1.050 1.040 | .763 | .100 | 1.040 | .975 | 1.125 | .103 | .070 | .250 | --- |
| 109L | .750-10 | 1.125-12UNF-2A | 1.050 1.040 | .763 | .100 | 1.040 | .975 | 1.250 | .103 | .070 | .250 | .490 |
| 110 | .875-9 | 1.250-12UNF-2A | 1.175 1.165 | .888 | .100 | 1.165 | 1.100 | 1.250 | .103 | .070 | .250 | --- |
| 110L | .875-9 | 1.250-12UNF-2A | 1.175 1.165 | .888 | .100 | 1.165 | 1.100 | 1.375 | .103 | .070 | .250 | .490 |
| 111 | 1.000-8 | 1.375-12UNF-2A | 1.300 1.290 | 1.015 | .100 | 1.290 | 1.225 | 1.375 | .103 | .070 | .250 | --- |
| 111L | 1.000-8 | 1.375-12UNF-2A | 1.300 1.290 | 1.015 | .100 | 1.290 | 1.225 | 1.500 | .103 | .070 | .250 | .550 |

MS51831G

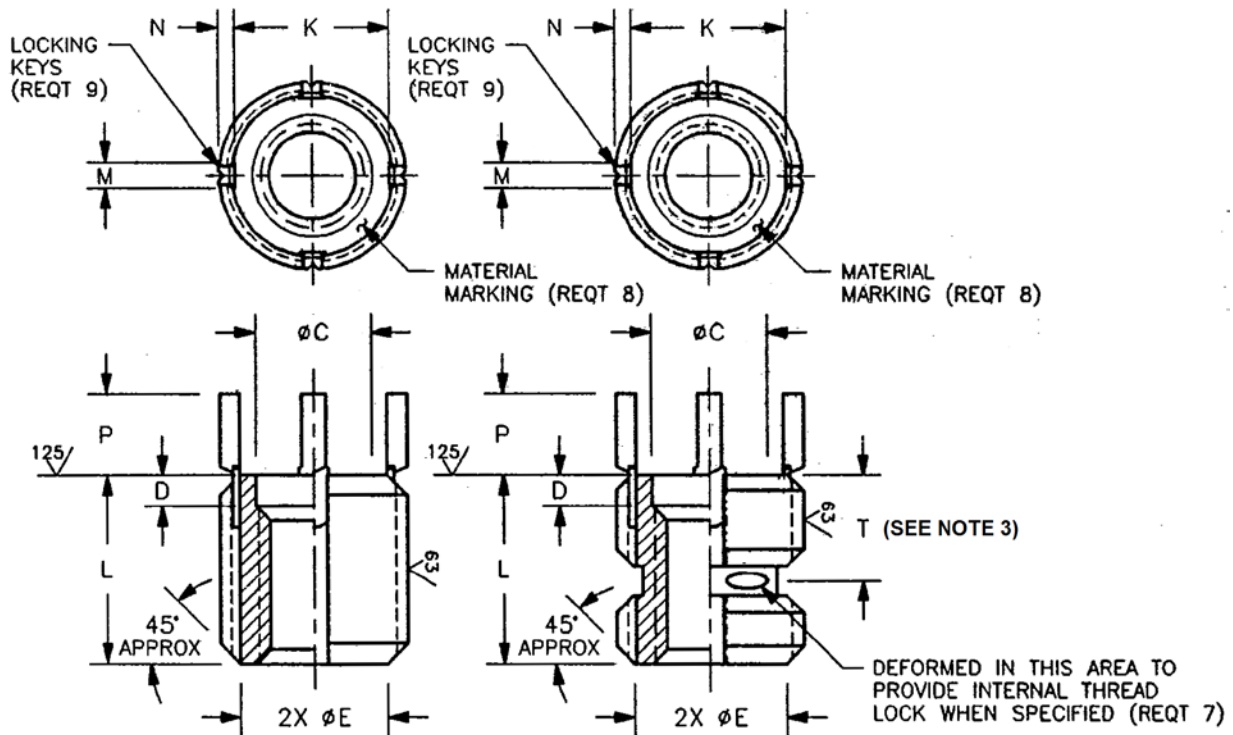

FIGURE 2. INSERT, FINE INTERNAL THREADS.

TABLE II. FINE INTERNAL THREADS.

| DASH NO. | INTERNAL THREAD SAE AS8879 UNJF-3B | EXTERNAL THREAD FED-STD-H28/2 EXCEPT MODIFIED MINOR DIA. | | ØC ±.005 | D ±.010 | ØE REF | K REF | L ±.015 | KEY DIMENSIONS | | | T ±.030 |
|----------|--|---|----------------|-------------|------------|-----------|----------|------------|----------------|----------|----------|------------|
| | | SIZE | MINOR DIA | | | | | | M REF | N REF | P REF | |
| 201 | .190-32 | .375-16UNC-2A | .320 .312 | .196 | .070 | .310 | .284 | .312 | .068 | .040 | .130 | .220 |
| 202 | .250-28 | .4375-14UNC-2A | .383 .375 | .257 | .070 | .375 | .344 | .375 | .068 | .040 | .190 | .220 |
| 203 | .3125-24 | .500-13UNC-2A | .440 .432 | .316 | .070 | .430 | .407 | .437 | .068 | .040 | .190 | .220 |
| 204 | .375-24 | .5625-12UNC-2A | .503 .495 | .380 | .070 | .495 | .469 | .500 | .068 | .040 | .190 | .250 |
| 205 | .4375-20 | .625-11UNC-2A | .565 .551 | .445 | .100 | .550 | .532 | .625 | .068 | .040 | .190 | .280 |
| 206 | .500-20 | .6875-11NS-2A | .625 .615 | .507 | .100 | .615 | .595 | .688 | .068 | .040 | .190 | .280 |
| 207 | .5625-18 | .8125-16UN-2A | .752 .744 | .580 | .100 | .745 | .720 | .812 | .068 | .040 | .190 | .320 |
| 208 | .625-18 | .875-14UNF-2A | .815 .807 | .640 | .100 | .805 | .782 | .875 | .068 | .040 | .190 | .330 |
| 209 | .750-16 | 1.125-12UNF-2A | 1.050 1.040 | .763 | .100 | 1.040 | .975 | 1.125 | .103 | .070 | .250 | --- |
| 209L | .750-16 | 1.125-12UNF-2A | 1.050 1.040 | .763 | .100 | 1.040 | .975 | 1.250 | .103 | .070 | .250 | .490 |
| 210 | .875-14 | 1.250-12UNF-2A | 1.175 1.165 | .888 | .100 | 1.165 | 1.100 | 1.250 | .103 | .070 | .250 | --- |
| 210L | .875-14 | 1.250-12UNF-2A | 1.175 1.165 | .888 | .100 | 1.165 | 1.100 | 1.375 | .103 | .070 | .250 | .490 |
| 211 | 1.000-12 | 1.375-12UNF-2A | 1.300 1.290 | 1.015 | .100 | 1.290 | 1.225 | 1.375 | .103 | .070 | .250 | --- |
| 211L | 1.000-12 | 1.375-12UNF-2A | 1.300 1.290 | 1.015 | .100 | 1.290 | 1.225 | 1.500 | .103 | .070 | .250 | .550 |

MS51831G

Requirements:

1. **Material.** Steel, corrosion-resistant, Type 303 (UNS 530300) in accordance with chemical composition of SAE AMS5640 (Type 1) or ASTM A582/A582M, or Type 303SE (UNS S30323) in accordance with chemical composition of SAE AMS5640 (Type 2), SAE AMS5738 or ASTM A582/A582M.

Steel, corrosion-resistant. Type A286 (UNS S66286) in accordance with SAE AMS5731, SAE AMS5734 or SAE AMS5737.

Steel, alloy, grade 4140 (UNS G41400) in accordance with SAE AMS6349 or SAE AMS6382 or grade 8740 (UNS G87400) in accordance with SAE AMS6322.

Locking keys: steel, corrosion-resistant. Type 302 chemical composition of ASTM A580/A580M only.

2. **Cadmium plating and surface treatment.** Corrosion-resistant steel shall be passivated in accordance with SAE AMS2700. Alloy steel shall be cadmium plated in accordance with SAE AMS-QQ-P-416, Type II, Class 3. The locking keys may or may not be cadmium plated.
3. **Lubrication.** Inserts with self-locking internal threads shall be dry film lubricated in accordance with MIL-PRF-46010, Type I. The locking keys may or may not be lubricated.
4. **Surface texture:** Machined surfaces shall be in accordance with ASME B46.1.
5. **Heat treatment:** Alloy steel inserts shall be heat treated to 160,000 psi Ft_u minimum in accordance with SAE-AMS-H-6875. Corrosion-resistant steel inserts, type A286 (SAE AMS5734). Shall be heat treated to 140,000 psi Ft_u minimum in accordance with SAE AMS-H-6875.
6. **Hardness.** Alloy steel inserts shall have a hardness range of 36-40 HRC.
7. **Part number.** The part number shall consist of the basic MS sheet number plus the dash number taken from Table I or Table II, as applicable:

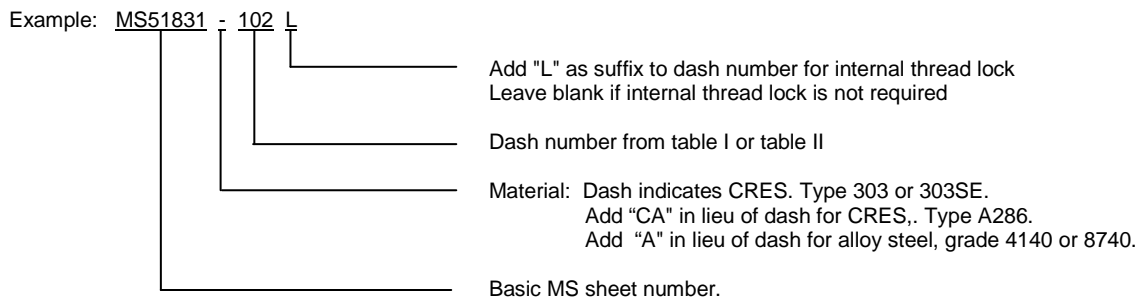

Example: MS51831CA102L indicates - Insert, Screw-Thread, Locked In, Key-Locked, Heavy Duty, CRES A286, .250-20UNJC-3B internal thread with internal thread lock feature.

8. **Material marking:** CRES 303 or 303SE has no identifying mark.
CRES A286 shall be identified on top of insert by one (1) line or dash mark.
Alloy steel 4140 or 8740 shall be identified on top of insert by two (2) parallel lines or dash marks.
9. Inserts with internal thread size .250 and smaller shall be supplied with two (2) locking keys spaced 180° apart.
Inserts with internal thread size .3125 and greater shall be supplied with four (4) locking keys spaced 90° apart.
10. Inserts shall be free of all hanging burrs and slivers which might become dislodged under usage.
11. **Source identification mark:** Source identification mark shall be in accordance with MIL-I-45914.
12. All dimensions are after cadmium plating or surface treatment and prior to the addition of the lubrication.
13. Fillets are R .015 maximum.

MS51831G

Notes:

1. All dimensions are in inches.
2. Installation of inserts shall be in accordance with MS51835.
3. Distance to center of internal thread lock.
4. In the event of a conflict between the text of this standard and the references cited herein, the text of this standard shall take precedence.
5. CHANGES FROM PREVIOUS ISSUE. Marginal notations are not used in this revision to identify changes with respect to the previous issue due to the extent of the changes.

MILITARY INTEREST

Custodians:

Army - AR
Navy - AS
Air Force - 99

Preparing activity:

DLA - IS

(Project 5325-2012-012)

Review activities:

Army – AT, AV, GL
Navy – MC, SH
Air Force - 71

NOTE: The activities listed above were interested in this document as of the date of this document. Since organizations and responsibilities can change, you should verify the currency of the information above using the ASSIST Online database at <https://assist.dla.mil>.

INCH-POUND

MS51832D
 14 August 2012
 SUPERSEDING
 MS51832C
 9 March 1992

DETAIL SPECIFICATION SHEET

INSERT, SCREW – THREAD, LOCKED IN, KEY-LOCKED,
 EXTRA HEAVY DUTY

This specification is approved for use by all Departments and Agencies of the Department of Defense.

The requirements for acquiring the product described herein shall consist of this specification sheet and procurement specification MIL-I-45914.

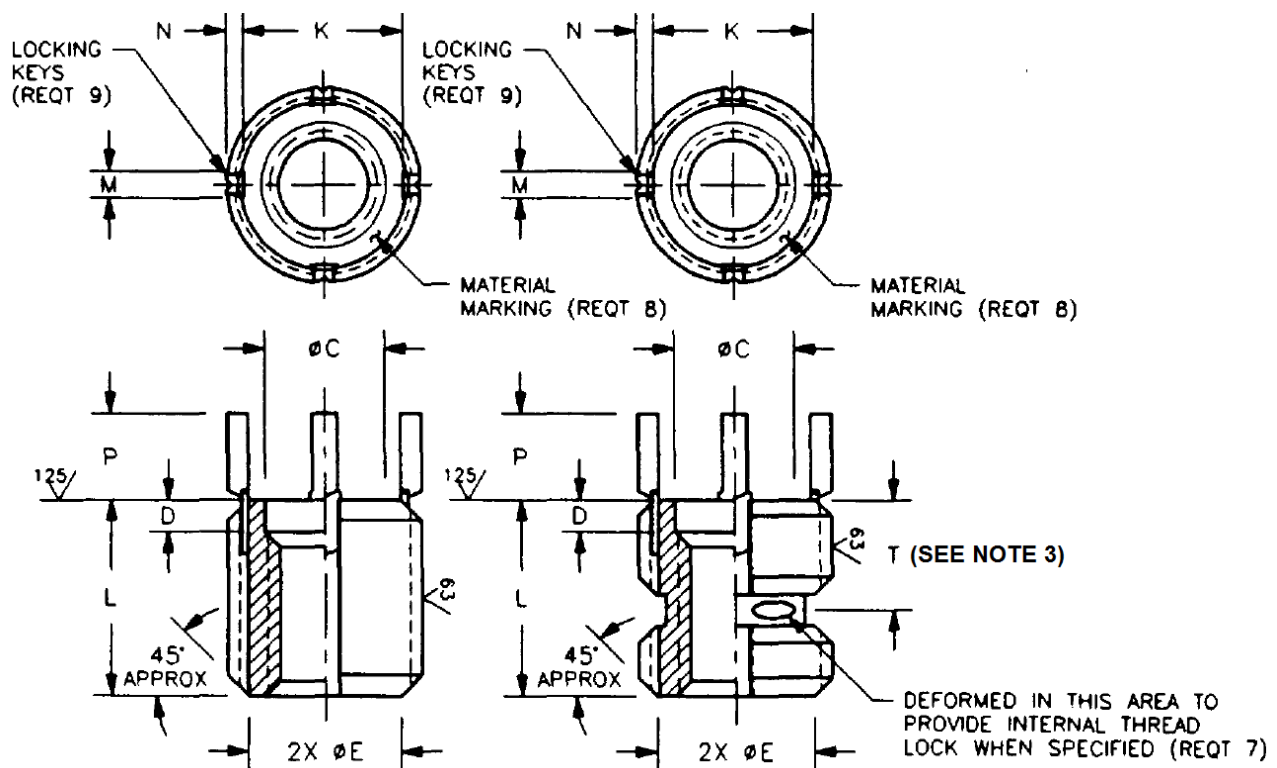

FIGURE 1. INSERT, COARSE INTERNAL THREADS.

MS51832D

TABLE I. COARSE INTERNAL THREADS.

| DASH NO. | INTERNAL THREAD SAE AS8879 UNJC-3B | EXTERNAL THREAD FED-STD-H28/2 EXCEPT MODIFIED MINOR DIA. | | ØC ±.005 | D ±.010 | ØE REF | K REF | L ±.015 | KEY DIMENSIONS | | | T ±.030 |
|----------|--|---|----------------|-------------|------------|-----------|----------|------------|----------------|----------|----------|------------|
| | | SIZE | MINOR DIA. | | | | | | M REF | N REF | P REF | |
| 101 | .190-24 | .4375-14UNC-2A | .383 .375 | .196 | .070 | .375 | .344 | .312 | .068 | .040 | .130 | .220 |
| 102 | .250-20 | .500-13UNC-2A | .440 .432 | .257 | .070 | .430 | .407 | .375 | .068 | .040 | .190 | .220 |
| 103 | .3125-18 | .5625-12UNC-2A | .503 .495 | .316 | .070 | .495 | .469 | .437 | .068 | .040 | .190 | .220 |
| 104 | .375-16 | .625-11UNC-2A | .565 .551 | .380 | .070 | .550 | .532 | .500 | .068 | .040 | .190 | .250 |
| 105 | .4375-14 | .6875-11NS-2A | .625 .615 | .445 | .100 | .615 | .595 | .625 | .068 | .040 | .190 | .280 |
| 106 | .500-13 | .8125-16UN-2A | .752 .744 | .507 | .100 | .745 | .720 | .688 | .068 | .040 | .190 | .280 |
| 107 | .5625-12 | .875-14UNF-2A | .815 .807 | .580 | .100 | .805 | .782 | .812 | .068 | .040 | .190 | .320 |
| 108 | .625-11 | 1.000-12UNF-2A | .924 .916 | .640 | .100 | .915 | .850 | .875 | .103 | .070 | .250 | .330 |
| 109 | .750-10 | 1.250-12UNF-2A | 1.175 1.165 | .763 | .100 | 1.165 | 1.100 | 1.125 | .103 | .070 | .250 | --- |
| 109L | .750-10 | 1.250-12UNF-2A | 1.175 1.165 | .763 | .100 | 1.165 | 1.100 | 1.250 | .103 | .070 | .250 | .490 |
| 110 | .875-9 | 1.375-12UNF-2A | 1.300 1.290 | .888 | .100 | 1.290 | 1.225 | 1.250 | .103 | .070 | .250 | --- |
| 110L | .875-9 | 1.375-12 UNF-2A | 1.300 1.290 | .888 | .100 | 1.290 | 1.225 | 1.375 | .103 | .070 | .250 | .490 |
| 111 | 1.000-8 | 1.500-12UNF-2A | 1.424 1.415 | 1.015 | .100 | 1.415 | 1.350 | 1.375 | .103 | .070 | .250 | --- |
| 111L | 1.000-8 | 1.500-12UNF-2A | 1.424 1.416 | 1.015 | .100 | 1.415 | 1.350 | 1.500 | .103 | .070 | .250 | .550 |

MS51832D

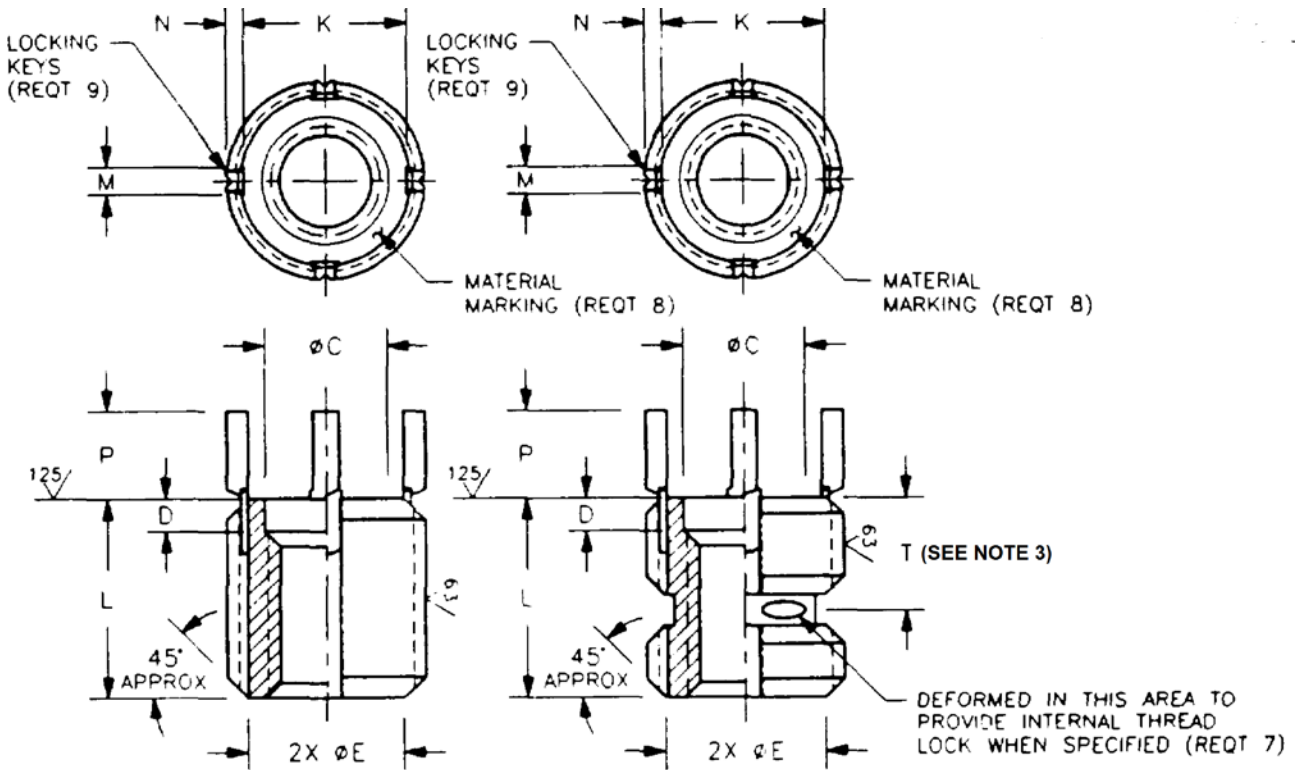

FIGURE 2. INSERT, FINE INTERNAL THREADS.

TABLE II. FINE INTERNAL THREADS.

| DASH NO. | INTERNAL THREAD SAE AS8879 UNJF-3B | EXTERNAL THREAD FED-STD-H28/2 EXCEPT MODIFIED MINOR DIA. | | ØC ±.005 | D ±.010 | ØE REF | K REF | L ±.015 | KEY DIMENSIONS | | | T ±.030 |
|----------|--|---|----------------|-------------|------------|-----------|----------|------------|----------------|----------|----------|------------|
| | | SIZE | MINOR DIA | | | | | | M REF | N REF | P REF | |
| 201 | .190-32 | .4375-14UNC-2A | .383 .375 | .196 | .070 | .375 | .344 | .312 | .068 | .040 | .130 | .220 |
| 202 | .250-28 | .500-13UNC-2A | .440 .432 | .257 | .070 | .430 | .407 | .375 | .068 | .040 | .190 | .220 |
| 203 | .3125-24 | .5625-12UNC-2A | .503 .495 | .316 | .070 | .495 | .469 | .437 | .068 | .040 | .190 | .220 |
| 204 | .375-24 | .625-11UNC-2A | .565 .551 | .380 | .070 | .550 | .532 | .500 | .068 | .040 | .190 | .250 |
| 205 | .4375-20 | .6875-11NS-2A | .625 .615 | .445 | .100 | .615 | .595 | .625 | .068 | .040 | .190 | .280 |
| 206 | .500-20 | .8125-16UN-2A | .752 .744 | .507 | .100 | .745 | .720 | .688 | .068 | .040 | .190 | .280 |
| 207 | .5625-18 | .875-14UNF-2A | .815 .807 | .580 | .100 | .805 | .782 | .812 | .068 | .040 | .190 | .320 |
| 208 | .625-18 | 1.000-12UNF-2A | .924 .916 | .640 | .100 | .915 | .850 | .875 | .103 | .070 | .250 | .330 |
| 209 | .750-16 | 1.250-12UNF-2A | 1.175 1.165 | .763 | .100 | 1.165 | 1.100 | 1.125 | .103 | .070 | .250 | --- |
| 209L | .750-16 | 1.250-12UNF-2A | 1.175 1.165 | .763 | .100 | 1.165 | 1.100 | 1.250 | .103 | .070 | .250 | .490 |
| 210 | .875-14 | 1.375-12UNF-2A | 1.300 1.290 | .888 | .100 | 1.290 | 1.225 | 1.250 | .103 | .070 | .250 | --- |
| 210L | .875-14 | 1.375-12UNF-2A | 1.300 1.290 | .888 | .100 | 1.290 | 1.225 | 1.375 | .103 | .070 | .250 | .490 |
| 211 | 1.000-12 | 1.500-12UNF-2A | 1.424 1.416 | 1.015 | .100 | 1.415 | 1.350 | 1.375 | .103 | .070 | .250 | --- |
| 211L | 1.000-12 | 1.500-12UNF-2A | 1.424 1.416 | 1.015 | .100 | 1.415 | 1.350 | 1.500 | .103 | .070 | .250 | .550 |

MS51832D

Requirements:

1. Material. Steel, corrosion-resistant, Type 303 (UNS S30300) in accordance with chemical composition of SAE AMS 5640 (Type 1) or ASTM A582/A582M, or Type 303SE (UNS S30323) in accordance with chemical composition of SAE AMS 5640 (Type 2), SAE AMS 5738 or ASTM A582/A582M.

Steel, corrosion-resistant. Type A286 (UNS S66286) in accordance with SAE AMS 5731, SAE AMS 5734 or SAE AMS 5737.

Steel, alloy, grade 4140 (UNS G41400) in accordance with SAE AMS 6349 or SAE AMS 6382 or grade 8740 (UNS G87400) in accordance with SAE AMS 6322.

Locking keys: steel, corrosion-resistant. Type 302 chemical composition of ASTM A580/A580M only.
2. Cadmium plating and surface treatment. Corrosion-resistant steel shall be passivated in accordance with SAE AMS2700. Alloy steel shall be cadmium plated in accordance with SAE AMS-QQ-P-416, Type II, Class 3. The locking keys may or may not be cadmium plated.
3. Lubrication. Inserts with self-locking internal threads shall be dry film lubricated in accordance with MIL-PRF-46010, Type I. The locking keys may or may not be lubricated.
4. Surface texture: Machined surfaces shall be in accordance with ASME B46.1.
5. Heat treatment: Alloy steel inserts shall be heat treated to 160,000 psi Ft_u minimum in accordance with SAE AMS-H- 6875. Corrosion-resistant steel inserts, type A286 (SAE AMS 5734). Shall be heat treated to 140,000 psi Ft_u minimum.
6. Hardness. Alloy steel inserts shall have a hardness range of 36-40 HRC.
7. Part number. The part number shall consist of the basic MS sheet number plus the dash number taken from table I or table II, as applicable:

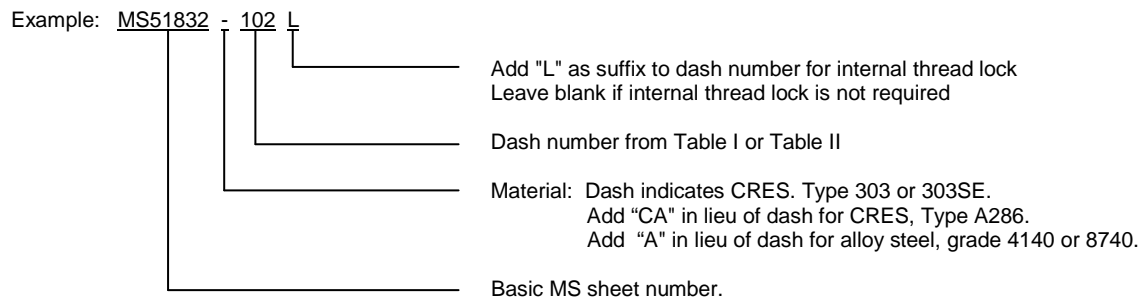

Example: MS51832CA102L indicates - Insert, Screw-Thread, Locked In, Key-Locked, Lightweight, CRES A286, .250-20UNJC-3B internal thread with internal thread lock feature.

8. Material marking: CRES 303 or 303SE has no identifying mark.
CRES A286 shall be identified on top of insert by one (1) line or dash mark.
Alloy steel 4140 or 8740 shall be identified on top of insert by two (2) parallel lines or dash marks.
Material marking of miniature type optional.
9. Inserts with internal thread size .190 and smaller shall be supplied with two (2) locking keys spaced 180° apart.
Inserts with internal thread size .250 and greater shall be supplied with four (4) locking keys spaced 90° apart.
10. Inserts shall be free of all hanging burrs and slivers which might become dislodged under usage.
11. Source identification mark: Source identification mark shall be in accordance with MIL-I-45914.
12. All dimensions are after cadmium plating or surface treatment and prior to the addition of the lubrication.
13. Fillets are R .015 maximum.

MS51832D

Notes:

1. All dimensions are in inches.
2. Installation of inserts shall be in accordance with MS51835.
3. Distance to center of internal thread lock.
4. In the event of a conflict between the text of this standard and the references cited herein, the text of this standard shall take precedence.
5. CHANGES FROM PREVIOUS ISSUE. Marginal notations are not used in this revision to identify changes with respect to the previous issue due to the extent of the changes.

MILITARY INTEREST

Custodians:

Army - AR
Navy - AS
Air Force - 99

Preparing activity:

DLA - IS

(Project 5325-2012-013)

Review activities:

Army – AT, AV, CR, MI
Navy – EC, MC, SH
Air Force - 71

NOTE: The activities listed above were interested in this document as of the date of this document. Since organizations and responsibilities can change, you should verify the currency of the information above using the ASSIST Online database at <https://assist.dla.mil>.